



SOUTHERN YELLOW PINE PROFILES

BEAUTIFUL DURABLE RENEWABLE



www.americansoftwoods.com

INTRODUCTION

Timber is increasingly popular as a practical way of adding character to a building because of its sustainability, its durability and its beauty. So much so that, in Europe, some grades are in short supply. What's more natural than to look to America's most popular wood, Southern Yellow Pine, for a readily available source of renewably produced timber, with distinctive looks and superior treatability?

Southern Yellow Pine is a generic term for four main species: loblolly, shortleaf, longleaf and slash pine. They grow mainly in the South East of the US in a wide geographic belt, stretching from East Texas to Virginia. Timber from all four species is classified as Southern Yellow Pine and graded in accordance with the grading rules of the Southern Pine Inspection Bureau (SPIB), approved by the American Lumber Standard Committee (ALSC).

A sustainable resource

Southern forests are abundant, healthy, and growing. Today's diverse ecosystem is primarily the result of management by private landowners, who own more than 80% of the South's forests. And because active forest management results in healthy tree growth,

Southern forests contribute significant environmental benefits, such as improved air and water quality, soil stabilization, shade, and a diverse wildlife habitat.

Landowners and sawmills throughout the South are increasingly choosing to work to certification standards, such as the Sustainable Forestry Initiative®, the American Tree Farm System, or ISO 14001.

A crucial part of good forest management is the replanting of trees. Through reforestation, future generations will benefit from the many products of healthy forests.

Contents

Boards and Finish	3
Exterior cladding	4-5
Ceilings and panelling	6-7
Flooring	8-9
Finishing	10-11



BOARDS AND FINISH

Boards

No. 2 Grade: Good quality, general purpose material suitable for cladding.



Finish

The distinctive grain and colour of Southern Yellow Pine make it particularly attractive for decorative applications, such as panelling and flooring, where natural finishes or stains are used.

The grade of Finish refers to its appearance.

Moisture content requirements for Finish timber varies by thickness (see Table 2).

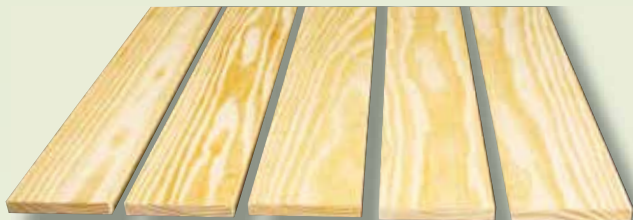

C&Btr. 1x6



D 1x6

Table 1: Finish grade characteristics

Grade	Characteristics
C&Btr. (C & Better)	Generally clear, although a limited number of pin knots are permitted. Satisfies requirements for high quality finish.
C	Excellent for painting or natural finish where requirements are less exacting. Reasonably clear, but a limited number of surface checks and small tight knots are permitted.
D	Economical and serviceable grade. Good quality for natural or painted finish.

Table 2: Finish timber moisture content

Nominal thickness	Moisture content
1" and 1¼"	Should not exceed 15%, unless specified as kiln-dried, when the maximum should be 12% on 90% of the pieces and 15% on the remainder.
1½", 1¾" and 2"	Maximum, 18%. Kiln-dried, 15%.
Over 2" but not over 4"	Maximum, 19%. Kiln-dried, 15%.
Over 4"	Maximum, 20%. Kiln-dried, 18%.

NOTE: Tables 1 and 2 are based upon SPIB Grading Rules, 2002 Edition.

EXTERIOR CLADDING

Exterior cladding

Three types of Southern Yellow Pine cladding, preservative treated for exterior use, are widely available: Shiplap, Tongue & Groove, and Log Cabin.

Shiplap cladding is machined in a variety of numbered patterns, such as #105 and #117.

Tongue & Groove is one of the more popular types of cladding for residential applications. It is generally manufactured with bevelled edges.

Log Cabin cladding simulates the appearance of actual logs and can be used for both exterior and interior applications.

Cladding installed horizontally, or at an angle, makes the structure appear lower and longer.

Southern Yellow Pine cladding, produced in accordance with SPIB Grading Rules, will be seasoned to a specific moisture content. See Table 2. When cladding is adequately seasoned and kept dry prior to proper installation and finishing, it will remain securely in place and is less likely to shrink or open at the joints.



1x8 C&Btr. Shiplap cladding #105



1x6 C&Btr. Shiplap cladding #117



1x6 C&Btr. T&G cladding #122



Log Cabin cladding



INSTALLATION GUIDELINES

Installation guidelines

Southern Yellow Pine cladding is easy to install, but it is essential to keep the wood dry before and during construction. It is also important to ensure the moisture content of the cladding matches the local climate as closely as possible so as to minimize dimensional changes after installation.

Courses of horizontal cladding should be spaced so that a single piece runs continuously above and below windows and doors without notching or splicing.

Cladding should be butted snugly and squarely against door and window casings, corner boards, and adjoining boards. Mitred corners should be precisely fitted, avoiding cavities where moisture could collect.

All nailing should be done into studs, and the total effective penetration of the nail should be at least 1½". Hot-dip galvanized, stainless steel, or other non-corrosive nails are recommended for fastening. Solid timber cladding should be fastened so that the boards are free to shrink and swell seasonally, reducing the tensile stresses that develop at the fasteners and often result in cracking and splitting.



Shiplap

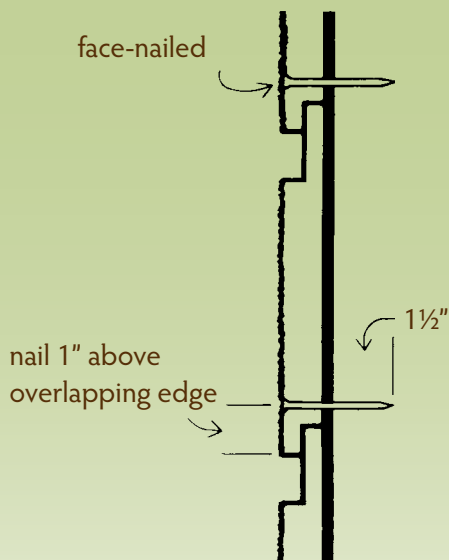

Boards 8" and wider require one additional nail in the centre.

Tongue & Groove

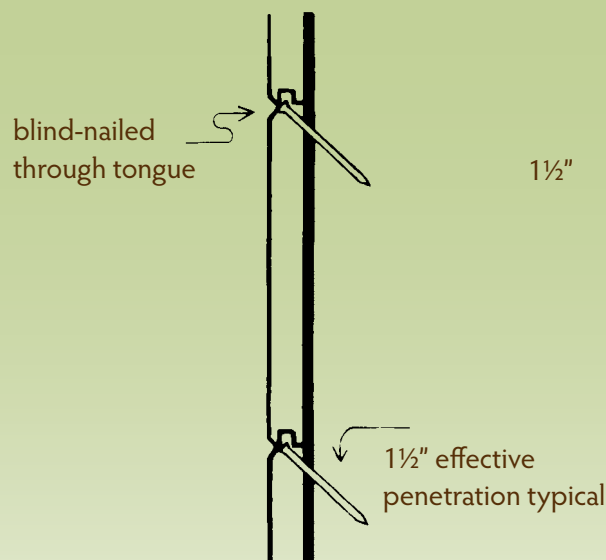

Boards 6" or wider are face-nailed with two 2½" (6.5cm) nails.

Log Cabin

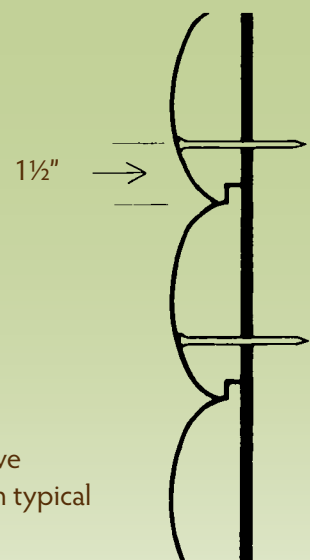

Nail 1½" up from lower edge of piece. For 8" and wider, use two nails, 3" to 4" apart.

CEILING AND PANELLING

Ceilings and panelling

Panelling is increasingly used to add character and warmth to interiors.

Southern Yellow Pine's distinctive raised double-beaded pattern is a classic for ceilings and panelling.

Profiles for ceilings and panelling are produced in a variety of grades. Finish grades of C&Btr. and D provide an excellent painting or staining surface. No.2 Board grade offers an economical solution for general purpose use and is well-suited to a more rustic effect.



1x4 C&Btr. T&G double-beaded ceiling



1x6 C&Btr. T&G centre bevel panelling #116



CEILING AND PANELLING



FLOORING

Flooring

Southern Yellow Pine's combination of rich colour, distinctive grain and resistance to normal wear makes it a popular choice for flooring. Flooring is available in a variety of sizes, grades and finishes, all tongue & groove.

Vertical or edge-grain flooring has a consistent, pinstripe grain with few knots, creating an almost formal appearance. It has a harder wearing surface than flat-grain material, making it suitable for high-traffic applications.

Typically more widely available than vertical-grain material, flat-grain flooring highlights the wood's unique colours, grain pattern, and growth characteristics, offering a rich and exceptional character that is unique to Southern Yellow Pine.

For optimum appearance, C&Btr. and D Finish grades provide an excellent flooring surface, suitable for a protective clear finish or staining. No.2 Boards offer an economical solution for general-purpose uses, complementing a more rustic décor.

Prefinished flooring

Prefinished Southern Yellow Pine flooring offers the convenience of a built-in finish, speeding-up project completion. Various widths, grades and finishes are available.



1x6 C&Btr. vertical-grain flooring



1x4 C&Btr. flat-grain flooring



1x6 No. 2 flat-grain flooring



Prefinished flooring

FLOORING



Stair treads

Stair treads

Southern Yellow Pine $\frac{5}{4}$ " x 12" bull-nosed stair treads provide a sturdy, durable and attractive surface that may be finished in the same manner as flooring.



FINISHING

One of the benefits of specifying Southern Yellow Pine is its ability to accept a wide variety of finishes. Before any type of finish is applied, make sure the wood is thoroughly clean and dry – and follow all instructions provided by the finish manufacturer.

Ceilings and panelling

Many homeowners prefer to bring out the distinctive grain of Southern Yellow Pine by applying a clear polyurethane finish to all exposed surfaces. These clear finishes are generally available in matt, satin, semi-gloss, or high gloss. Southern Yellow Pine readily accepts solid or semi-transparent stains, too. For painting, use a coat of primer plus two coats of a good quality water-based acrylic paint.

Exterior cladding

- For maximum durability, use pressure-treated timber. Otherwise treat all surfaces with a water-based preservative, taking special care to treat the end-grain. Caulk all joints and cracks. Allow time to dry thoroughly.
- Prime bare wood as soon as possible.
- Apply two coats of a good quality water-based acrylic exterior paint over the primer.
- Avoid future separation between paint coats by applying the first topcoat within two weeks of the primer, and the second coat within two weeks of the first.

Solid colour stains act much like paint and may be applied to a smooth surface with a brush, roller, or pad. Use two coats of a water-based acrylic stain.



Unlike paint, solid colour stains may leave overlap marks. Water-based acrylic stains are fast-drying and more likely to show overlap marks than oil-based stains. To prevent this, stain only a small number of boards at a time.

Oils and semi-transparent penetrating stains may be applied using a brush, sprayer, or roller. Brushing will usually provide better penetration and performance. Spraying, followed by back-brushing, is also a good method of application. For optimum service on rough-sawn or weathered timber, use two coats, applying the second coat before the first one is dry.

Semi-transparent, water-based acrylic stains do not penetrate the wood surface, but are easy to apply and less likely to form overlap marks. Application of two coats is recommended.



FINISHING

Flooring

Floor finishes provide both a protective and decorative surface. One option is to use a stain, available in a wide range of colours. If the new floor is not stained, a penetrating or surface protective sealer should be applied. Typically, penetrating sealers are floor oils and waxes that enhance the natural colour and grain of the wood while providing protection against dirt and liquids. Small chips and scratches can be removed with wax. On new floors, a liquid polishing wax can be applied to a wax finish to form an additional barrier to dirt and stains. Read the polishing wax label carefully to make certain it is suitable for wood floors. Do not use any product containing water. Waxes and oils will need regular maintenance.

Surface sealers, such as polyurethanes, moisture-cured urethanes and acid-cured urethanes, create a protective surface layer bonded to the wood.

Polyurethanes, with high gloss, semi-gloss, matt or satin finishes are the most popular surface sealers. Available in oil and water-based formulations, they provide good durability and moisture resistance. Although they offer excellent resistance to water, scuff marks and scratches, and provide a durable finish for high-traffic areas such as hallways, kitchens, bathrooms, and family rooms, polyurethane finishes have a tendency to 'yellow' as they age. When regular maintenance no longer



provides satisfactory floor surface appearance, sanding is recommended before applying a new coat.

Moisture-cured and acid-cured urethanes are the hardest of the surface sealers, but also the most difficult to apply. Do not attempt to apply urethane sealers without the supervision of an experienced floor finisher.

The selected finish will affect how often the floor needs cleaning. A lighter floor will make a room look brighter, more spacious and modern. It will hide dust better, but show up dirt and spills. A darker floor will tend to conceal dirt, heel marks and furniture scratches. It will have greater character and warmth, but make the room look smaller.



REFERENCE GUIDE

Table 3: Boards and profiles quick reference guide

	Grade				Moisture content	Nominal thickness	Nominal width
	C&Btr.	C*	D	No.2			
Boards SPIB rule 260				•	15%, 19%	1" to 1-½"	2" to 12"
Finish SPIB rule 200	•	•	•		12%, 15% or 19%	¾" to 4"	2" to 16"
Shiplap cladding SPIB rule 220	•	•	•	•	12%, 15% or 19%	⅝" to 1"	4" to 12"
T&G cladding SPIB rule 253	•	•	•	•	12%, 15% or 19%	½" to 1"	4" to 8"
Ceiling SPIB rule 250	•	•	•	•	12%, 15% or 19%	⅜" to ¾"	3" to 6"
Panelling SPIB rule 240	•	•	•	•	12%, 15% or 19%	1"	3" to 12"
Flooring SPIB rule 210	•	•	•	•	12%, 15% or 19%	⅜" to 1-½"	2" to 6"

*Produced in limited quantities

The samples pictured in this publication include examples of allowable characteristics within each grade, as described in Standard Grading Rules for Southern Pine Lumber, 2002 Edition, published by the Southern Pine Inspection Bureau (SPIB). A complete timber grade description should be included with any buyer's order, and is considered an agreement between buyer and seller of specific characteristics allowed within each grade purchased.

The conditions under which timber is used in construction may vary widely, as does the quality of workmanship. Neither Southern Forest Products Association (SFPA) nor its members have knowledge of the quality of workmanship or construction methods

used on any construction project and, accordingly, do not warrant the design or performance of the timber in completed structures.

The content of this publication has been compiled by the SFPA as a service to buyers, users, and specifiers of wood building materials. The SFPA is a non-profit trade promotional group supported by Southern Yellow Pine timber manufacturers. One of the primary missions of the council is to provide information to those interested in the industry's products. SFPA neither grades, tests, manufactures, nor treats timber products. SFPA does not warrant the technical data, timber design or performance in completed structures.

SFPA's global representatives are ready to assist with product or technical information. Find regional contacts at www.SouthernPineGlobal.com

Southern Forest Products Association
2900 Indiana Avenue
Kenner, LA 70065 USA

Tel: 001-504-443-4464
Email: info@americansoftwoods.com



www.americansoftwoods.com